

Comparison of LED Circuits

Application Note

Introduction

In recent years, Light Emitting Diodes (LEDs) have become a viable alternative to conventional light sources. The overriding advantages long life, high efficiency, small size and short reaction time have led to the displacement, in ever increasing numbers, of incandescent bulbs. One of the markets where this change has become most evident is Automotive, where LEDs are used now not only for backlighting dashboards and switches, but also for exterior illumination in Center High Mounted Stop Lights (CHMSL), Rear Combination Lamps (RCL), turn signals and puddle lighting.

Despite the long life and low failure rates of LEDs, cars can be found, on occasion, with failed LEDs in their CHMSL. Most often this is due to a flawed circuit design wherein the LEDs were allowed to be overdriven. It is with that supposition in mind that this application note is written: to identify, characterize and comment on LED behavior and failure modes in serial and matrix circuits.

Failure modes of LEDs

Ultimately there are two possible failure modes for LEDs: light degradation and total failure. Light degradation occurs when the emitted light falls to 50% of its' initial value. This is due simply to aging of the LED. The second failure mode, total failure, is caused by an open contact between the Chip and the lead frame, between the Chip and the bond wire or between the bond wire and the lead frame. The reason for this failure is an overheating of the LED past the glass point of the resin. This leads to a softening of the resin, and when the resin material cools and becomes hard once again, mechanical

forces on the bond wire cause an open contact.

Electrical characteristics of the LED and forward voltage grouping

The characteristics of LED forward voltage have similar electrical properties to that of any other diode, which is: 1) a forward voltage threshold must be reached before the diode will begin conducting, 2) that there is a thermal coefficient for forward voltage and 3) that the diode is nonconductive in reverse.

In order to meet the exacting standards of light-output and consistency typical in automotive exterior illumination, it is necessary to segregate the forward voltage of the LEDs used in these applications into groups. By tightly controlling the parameter of voltage in such a way, uniformity in appearance is better achieved in the end application.

Exemplary voltage groups of the Power TOPLED LA E67B (which will be used in the simulations to follow) are shown below:

Voltage group and values:

3A: $V_f = 1.90V - 2.05V$, ($V_{f,typ} = 1.975V$)

3B: $V_f = 2.05V - 2.20V$, ($V_{f,typ} = 2.125V$)

4A: $V_f = 2.20V - 2.35V$, ($V_{f,typ} = 2.275V$)

4B: $V_f = 2.35V - 2.50V$, ($V_{f,typ} = 2.425V$)

Simulation of different LED circuits

To demonstrate LED performance in a circuit, two simulations have been performed for each circuit topology: one being a typical simulation with all LEDs performing normally, and the second, a simulation with one (1) failed LED in the circuit. The failed LED is invariably from a string with typical forward voltage.

For each of the circuit simulations to follow, the proceeding parameters will be considered constant:

1. Sixteen (16) LA E67B Power TOPLED LEDs with a voltage group 3B ($V_f = 2.125V @ 50mA$) have been used, wherein four (4) LEDs are in parallel and four (4) LEDs are in series.
2. The LED strings for each circuit have been arranged from left to right in a minimum, mean (definition: mid), maximum arrangement of forward voltage. This equates to a forward voltage of $2.05V @ 50mA$ for the left most string, a forward voltage of $2.125V @ 50mA$ for the middle two strings, and a forward voltage of $2.20V @ 50mA$ for the right most string.

3. The LEDs have been driven by a voltage source of $12.8V DC$. (This is equivalent to a voltage source of $13.5V DC$, minus a $0.7V$ drop at a reverse protection diode.)
4. The resistors have been chosen so that for the typical voltage bin of 3B ($V_f = 2.125V @ 50mA$), a current of $50mA$ flows for every LED. (The resistor values are theoretically calculated.)
5. The simulations have been carried out at an ambient temperature of $25^{\circ}C$.
6. The simulation results were recorded instantaneously, after having had current applied directly from a power supply.

Additional note: Thermal effects, though not been taken into consideration for the individual simulations, are discussed, generally, at the end of this application note.

Circuit Topology 1: matrix circuit with one resistor for the complete circuit

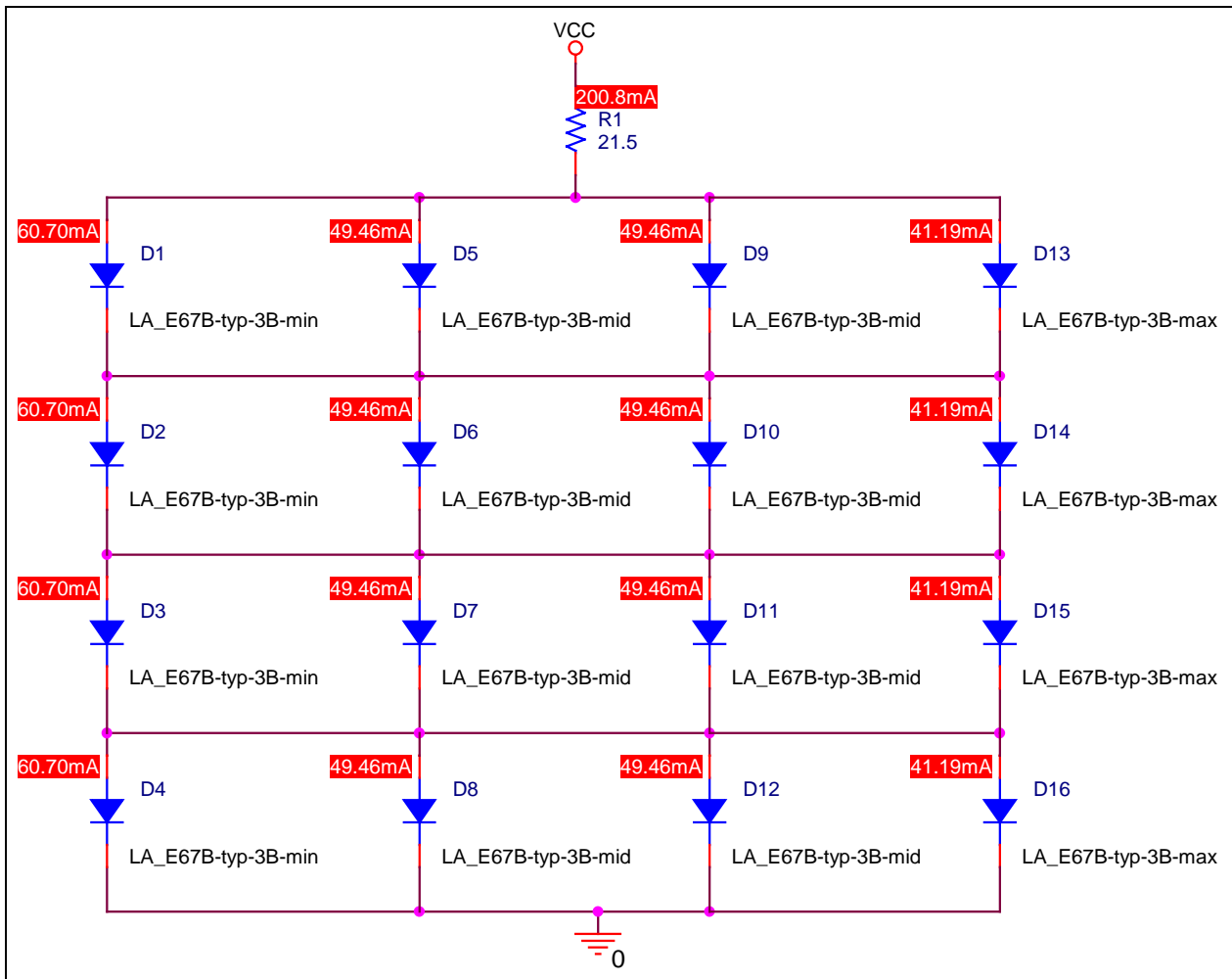

Figure 1 Circuit Topology 1: matrix circuit with one resistor for the complete circuit

Results:

As calculated, the forward current for the LEDs with the typical forward voltage of group 3B is 49.46mA (~50mA). For the LEDs from the lower forward voltage group, the forward current is 60.70mA. For the LEDs from the upper limit of the voltage group, the forward current is 40.19mA. In the worst case, the overall current variation in this circuit is $50\text{mA} \pm \sim 20\%$. This leads to a variation of the brightness which can be seen by the customer.

The forward voltages of the LEDs have a negative temperature coefficient ($T_k = -3.7\text{mV/K}$). Accordingly, as the temperature increases, the forward voltage decreases while the forward current increases. In the case of this simulation, the current for the LEDs with 60.70mA would increase more than for the LEDs with 41.19mA. The variation of current within the complete circuit would therefore increase.

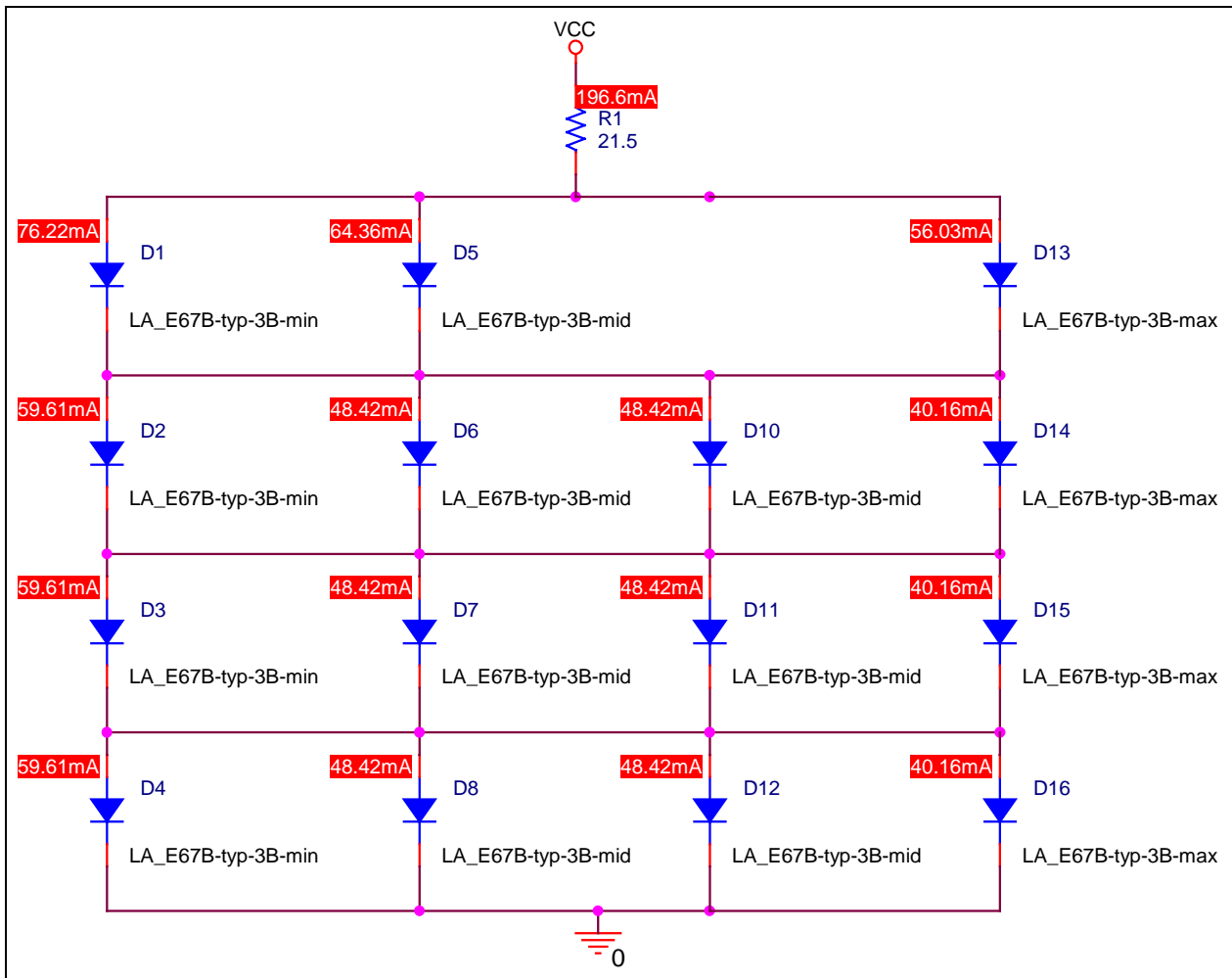

Figure 2 Circuit Topology 1: matrix circuit with one resistor for the complete circuit, one LED failed

Results:

When one LED fails, two effects can be observed: first, the total current flowing through the complete matrix drops slightly as the equivalent resistance of the circuit increases. Second, and more significantly, the three LEDs that are parallel to the failed LED pull more current. In the worst case this means that a LED from the lower limit of the voltage group will pull 76.22mA. This current exceeds the maximum specified value of 70mA for the LA E67B.

Advantages of the matrix circuit with one resistor for the complete circuit:

- If one LED fails, the remaining LEDs still operate.

- Simple circuit design, comparatively low cost for the resistors.

Disadvantages of the matrix circuit with one resistor for the complete circuit:

- In the worst case, as illustrated in the above simulation, the current distribution can be very unsymmetrical. Because of the differences in current, the LEDs do not experience a consistent rise in temperature across the circuit.
- The failure of one LED leads to an overdriving of the remaining LEDs to which it was in parallel. This effect is increased when fewer diodes are in parallel, and, when combined with the effects of temperature referenced above,

will compromise uniformity to the rest of the circuit and shortened overall life.

- Due to the small change in current registered by the failure of a single LED,

the failure can not be easily or economically detected by current sense; only the failure of the complete circuit can be detected.

Circuit Topology 2: serial circuit

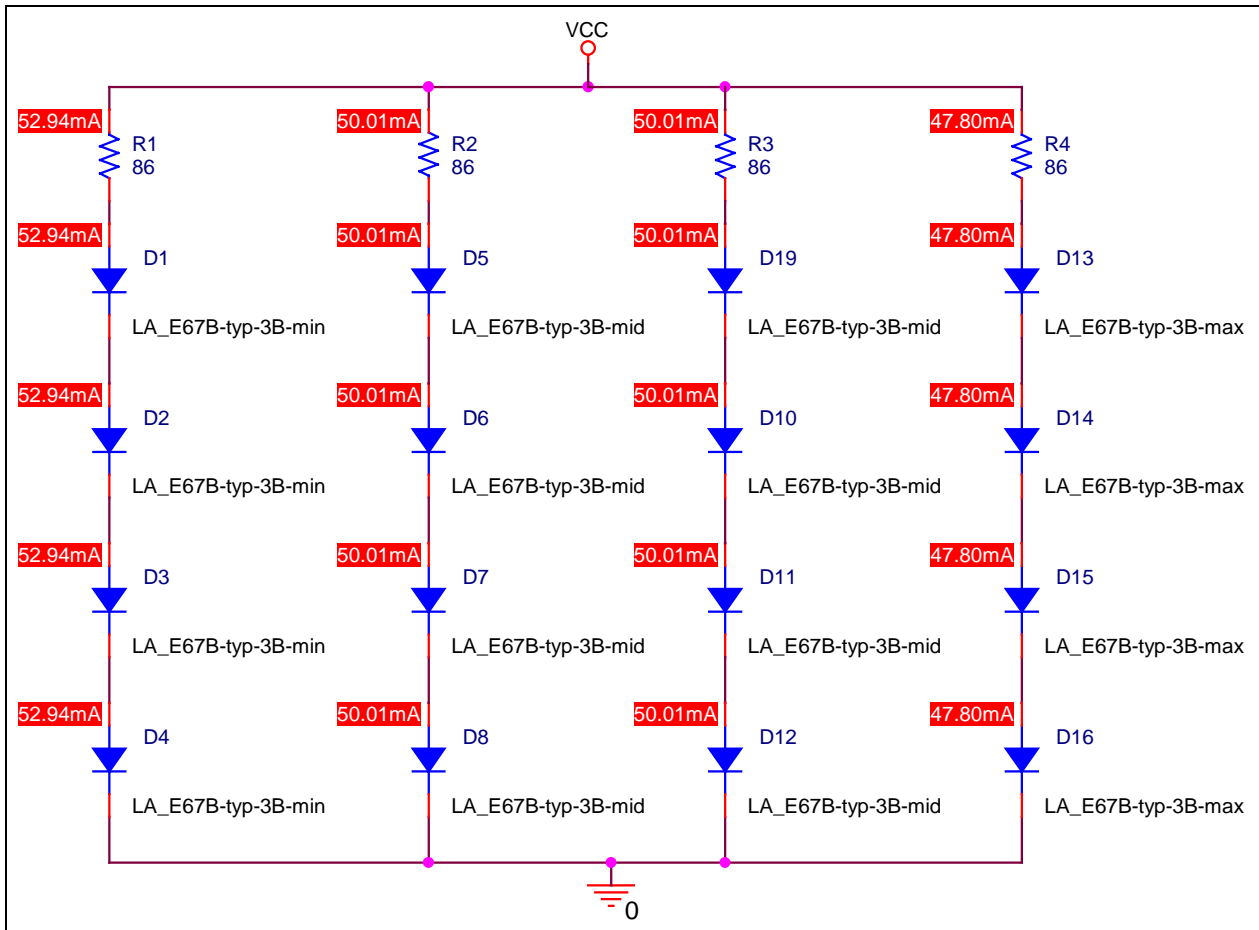

Figure 3: Circuit Topology 2: serial circuit

Results:

The forward current of the LEDs from the typical forward voltage of group 3B is 50.01mA (~50mA). For the LEDs from the lower forward voltage group, the forward current is 52.94mA. For the LEDs from the upper limit of the forward voltage group, the forward current is 47.80mA. In the worst

case, the overall current variation in this circuit is 50mA ± ~5%.

The subsequent effect of temperature on appearance is less profound in this circuit than in Circuit Topology 1 due to less variation in the forward current of the LEDs.

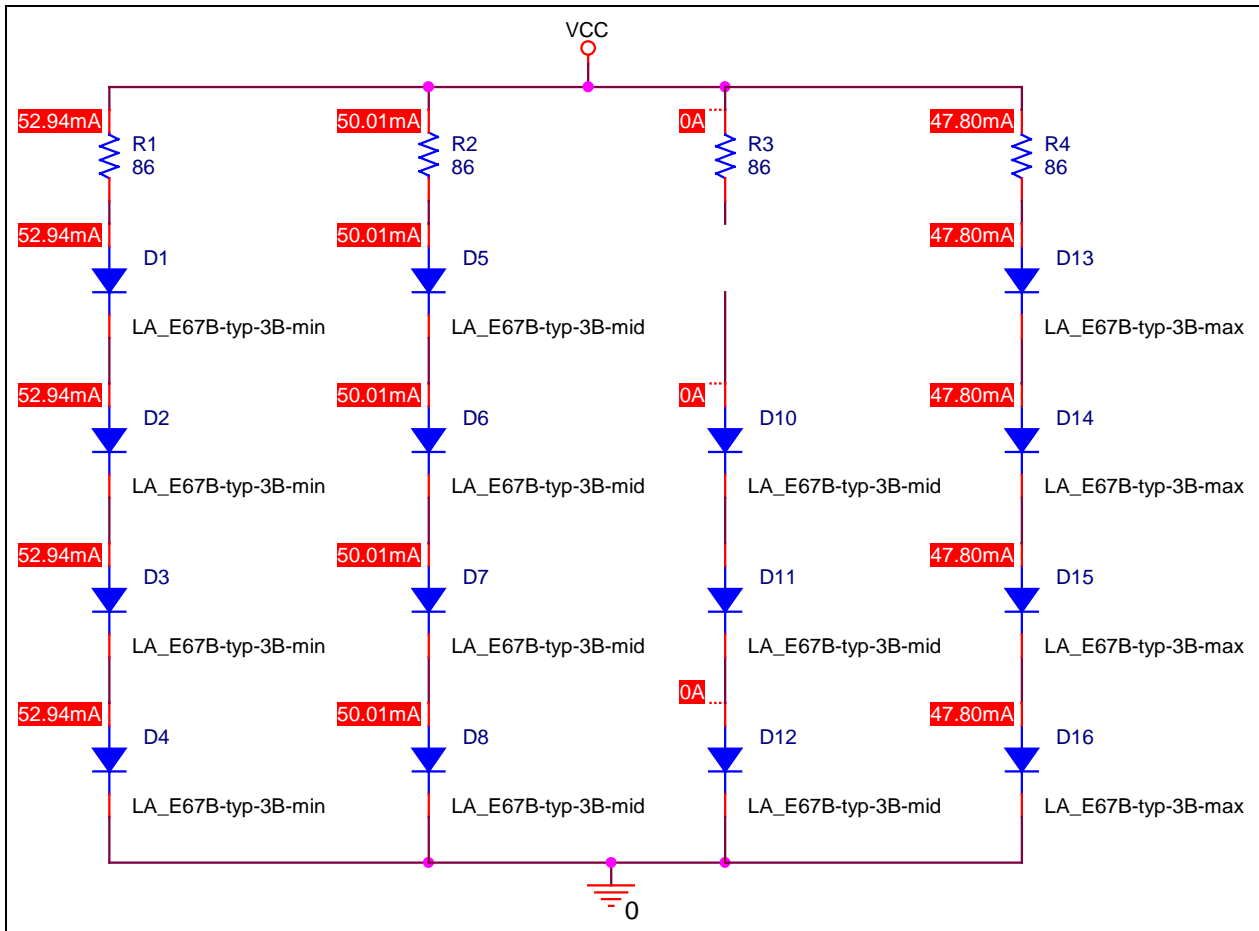

Figure 3: Circuit Topology 2: serial circuit, one LED failed

Results:

The failure of one LED causes the remaining LEDs in that string to fail. As a result, the total current drops from 200mA to 150mA, approximately. The current of the LEDs in the remaining strings is unaffected.

Advantages of the serial circuit:

- The current for each string can be adjusted very accurately by the resistors.
- Simple circuit design, comparatively low cost for resistors.
- The failure of one LED string will not affect the current of the remaining LED strings.
- Due to the significant change in current registered by the failure of a complete string of LEDs, complex failure detection using current sense is made possible.

Disadvantages of the serial circuit:

- The failure of a single LED will cause the remaining LEDs in that string to fail.

Additional Thermal considerations

In automotive applications, it is understood that the ambient temperature (T_a) is specified up to 85°C. For the LA E67B the temperature coefficient of the forward voltage (TC_V) equates to -3.7 mV/K. Thus the forward voltage of a LA E67B working in an ambient temperature of 85°C drops. This voltage drop (V_D) can be calculated as the product of the temperature rise (Tr) and the temperature coefficient as shown below:

$$V_D = Tr * TC_V = 60K * (-3.7mV/K) = 0.22V$$

Calculations and measurements show that this voltage drop (V_D) leads to an increase in forward current of between 10-20% of the value at 25°C for every LED. Thus, an LED that draws a current of 50mA at 25°C would draw a current of 55-60mA at 85°C.

Conclusions

Essentially, there are two ways to design a cluster of LEDs: a serial circuit or a matrix circuit with one resistor for the entire circuit. Each of these possibilities has advantages and disadvantages (see Table 1 and 2) that will be dependent upon the end application and the respective requirements therein.

	Serial circuit	Matrix circuit with one resistor for the complete circuit
Advantages	The current for each string can be adjusted very accurately by the resistors.	If one LED fails, the remaining LEDs still operate.
	Simple circuit design, comparatively low cost for resistors.	Simple circuit design, comparatively low cost for the resistors.
	The failure of one LED string will not affect the current of the remaining LED strings.	
	Due to the significant change in current registered by the failure of a complete string of LEDs, complex failure detection using current sense is made possible.	

Table 1: Advantages of the different circuit topologies

	Serial circuit	Matrix circuit with one resistor for the complete circuit
Disadvantages	The failure of a single LED will cause the remaining LEDs in that string to fail.	In the worst case the current distribution can be very unsymmetrical. Because of the differences in current, the LEDs do not experience a consistent rise in temperature across the circuit.
		The failure of one LED leads to an overdriving of the remaining LEDs to which it was in parallel. This effect is increased when fewer diodes are in parallel, and, when combined with the effects of temperature referenced above, will compromise uniformity to the rest of the circuit and shortened overall life.
		Due to the small change in current registered by the failure of a single LED, the failure can not be easily or economically detected by current sense; only the failure of the complete circuit can be detected.

Table 2: Disadvantages of the different circuit topologies

For each circuit topology, especially so for Circuit Topology 1 (Figures 1 and 2), the distribution of current within the circuit is critical. Care must be taken in the design of the circuit so that the LEDs do not get overdriven, for as current increases, so to does temperature. This self heating effect:

increasing current resulting in increasing temperature, resulting in increasing current until such a point as equilibrium is reached, is exacerbated in Circuit Topology 1 by having just the single resistor for the entire circuit.

Author: Markus Hofmann, (with Mark Byrne)

About Osram Opto Semiconductors

Osram Opto Semiconductors GmbH, Regensburg, is a wholly owned subsidiary of Osram GmbH, one of the world's three largest lamp manufacturers, and offers its customers a range of solutions based on semiconductor technology for lighting, sensor and visualization applications. The company operates facilities in Regensburg (Germany), San José (USA) and Penang (Malaysia). Further information is available at www.osram-os.com

All information contained in this document has been checked with the greatest care. OSRAM Opto Semiconductors GmbH can however, not be made liable for any damage that occurs in connection with the use of these contents.